

MODEL 2500D MODEL 2501D

3-Phase Monitor

- Monitors for Phase Loss or Reversal, Low Voltage or Voltage Unbalance
- Automatic Reset
- Heavy Duty DPDT Output Contacts
- UL Listed to U.S. and Canadian Safety Standards



DESCRIPTION

The Models 2500D and 2501D 3-Phase Monitors are designed to continuously monitor the voltages of a 3-phase power distribution system for abnormal conditions. The monitors feature solid-state voltage and phase angle sensing circuits which drive a DPDT electromechanical output relay. A neutral connection is **not** required with either the Model 2500D or 2501D. This allows each model to be connected to any three phase WYE or DELTA configured power distribution system.

When the correct voltage and phase sequence is applied to a specified Model 2500D, the output relay **will not energize**. An under voltage, phase reversal, phase unbalance or phase loss condition **will cause** the output relay to **energize**, even if regenerated voltage is present. Complete power loss **will not cause** Model 2500D to trip.

When the correct voltage and phase sequence is applied to a specified Model 2501D, the output relay **will energize**. An under voltage, phase reversal, phase unbalance, or phase loss condition **will cause** the output relay to **de-energize**.

Each option on the Model 2500D or 2501D is adjustable throughout its operating range. The adjustment pots and LED indicators for VOLTAGE ADJUST, UNBALANCE ADJUST and TIME DELAY are mounted on the front of the unit, for easy access.

Seven versions of both the Model 2500D and the Model 2501D cover voltage ranges from 120 to 600 VAC. All models are UL Listed to U.S. and Canadian safety standards.

SPECIFICATIONS

Model 2500D-XXX Model 2501D-XXX	-120	-208	-240	-380	-415	-480	-600
Nominal AC Voltage	120	208	240	380	415	480	600
Adjustment Range	84-114V	146-198V	168-229V	266-361V	290-394V	336-456V	420-570V
Frequency	50/60Hz						
Unbal. adj range	2 to 10% per NEMA specifications						
Trip Delay adj range	1 to 10 seconds (1 second increments)						
Power Consumption	4.5W per phase						
Repeat Accuracy	± 1% of full scale						
Reset Time	150ms nominal						
Reset Type	Automatic						
Dead Band	2% of full scale						
Output Contacts	DPDT 40 amps at 28VDC/300VAC 50/60Hz 5 amps at 480/600VAC 50/60Hz						
Operating Temp	- 4° to +131° F						
Humidity Tolerance	0-97% without condensation						
Enclosure Material	ABS plastic						
Weight	2 lbs. 5 oz.						
Mounting	Surface						
Agency Approval	UL Listed to U.S. and Canadian safety standards						

TYPICAL APPLICATION - Motor Protection

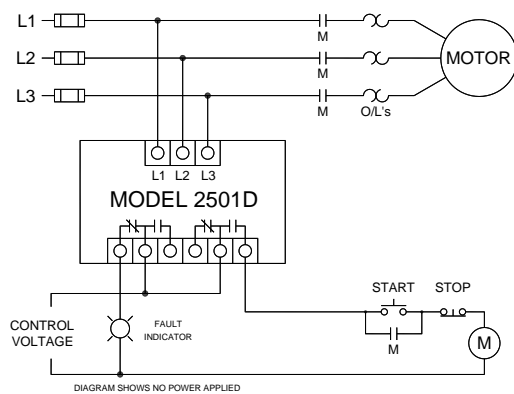

DIMENSIONS

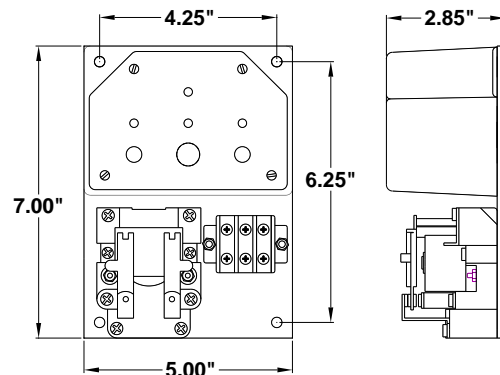

MODEL 2500D MODEL 2501D

3-Phase Monitor

READ ALL INSTRUCTIONS BEFORE INSTALLING, OPERATING OR SERVICING THIS DEVICE.
KEEP THIS DATA SHEET FOR FUTURE REFERENCE.

Installation Instructions

DANGER

- HAZARD OF ELECTRIC SHOCK, BURN OR EXPLOSION
- POWER CONTROL & INSTRUMENT CIRCUITS MAY BE SUPPLIED BY REMOTE SOURCES
- THIS DEVICE SHOULD ONLY BE INSTALLED OR SERVICED BY QUALIFIED PERSONNEL
- TURN OFF ALL POWER SUPPLYING THIS DEVICE BEFORE WORKING ON MONITOR
- FAILURE TO DO SO WILL RESULT IN DEATH OR SEVERE PERSONAL INJURY

INSTALLATION

Mount the Model 2500D or 2501D in a stable location, observing all precautions outlined in the statement above. Mounting hardware is not included.

Connect the control wiring to the terminals with the contact markings (refer to the diagram on the unit). Markings shown on the unit are in the power off condition. Apply power.

If the contacts transfer (NORMAL indicator-Off), check the LOW, REVERSE, and UNBALANCE indicators for a possible fault condition. If no indicators are lit, check that all three phases are present and of the correct voltage.

If all phases are correct and the LOW indicator is ON, rotate the VOLTAGE ADJUST until the light just goes out.

If the UNBAL indicator is ON, rotate the UNBAL ADJUST until the light just goes out.

NOTE: During adjustment you may find the UNBAL ADJUST and the TRIP DELAY adjustment has no effect. Check for phase loss.

If the REVERSE indicator is ON, remove power and reverse any two of the three input wires and re-apply power. The NORMAL indicator will light.

ADJUSTMENT

Note: During adjustment, you may want to install a jumper across the control contacts or open circuit, depending on your control configuration, to prevent cycling the load on and off.

Rotate the VOLTAGE ADJUST to the desired percent of nominal voltage, or slowly clockwise, until the contacts transfer to the failed condition (LOW indicator-ON).

Slowly turn the adjustment counter-clockwise until the contacts reset to the normal condition (LOW indicator-OFF; NORMAL indicator-ON).

Remove the jumper from the control contacts, if installed.

This setting will be correct for most applications. If nuisance tripping occurs, turn the VOLTAGE ADJUST slightly counter-clockwise, or increase the trip delay time.

Any adjustments to the VOLTAGE ADJUST, to eliminate nuisance tripping, should be made in small increments, until the *true* nuisance trips are eliminated. Adjust the TRIP DELAY and UNBAL ADJUST as required by the system.

TYPICAL APPLICATION - Shunt Breaker

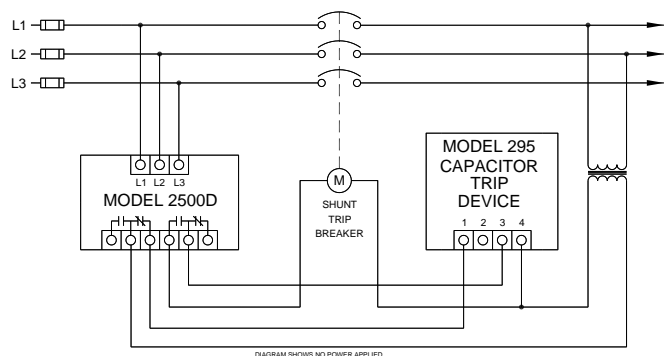

WARRANTY

This product is warranted to be free from defects in materials and workmanship, and is covered by our exclusive **5-year Unconditional Warranty**. Should this device fail to operate for any reason, we will repair it for five years from the date of manufacture. For complete warranty details, see the *Terms and Conditions of Sales* page in the front section of the Time Mark catalog or contact Time Mark at 1-800-862-2875.



TIME MARK
CORPORATION

11440 East Pine Street
Tulsa, Oklahoma 74116

08/18
© 2018 TIME MARK CORPORATION

TIME MARK is a division of  AEMT, Inc.